

## BOOST DC/DC CONVERTER CONTROL BASED ON FUZZY LOGIC

\*\* Jawad Radhi \*, Dr. Ramzy S. Ali\*, & Dr. Ali Fathel  
\*\*Dept. Of Electrical Engineering , Basrah University  
\*Dept. Of Computer Science , Basrah University

**Abstract:** This paper proposes a fuzzy logic based controller for boost type DC/DC converter. It forms an improvement to the dynamic performances of the well known PI like fuzzy controller which uses the output voltage error & its rate of change as an inputs.

The proposed controller generates a duty ratio control signal through the addition of a weighted part of the input voltage and of the low pass filtered signal of the inductor current to that of the fuzzy controller which is fed by voltage error and a signal representing the differences of the output voltage from its low pass filtered version .

The controlled boost DC/DC converter exhibited excellent performances under small and larger disturbances of the input voltage and output load resistance and also showed good reference tracking ability.

### السيطرة المضببة لمحول تيار تيار مستمر DC/DC من النوع الرفع جواد راضي, د. رمزي سالم علي و د. علي فاضل

الخلاصة : يقترح هذا البحث مسيطر محول تيار مستمر من النوع الرفع يعتمد منطقاً مضبباً . هذا المسيطر يحسن الاداء الحركي للمسيطر المضبب المعروف بـ "PI like fuzzy controller" والذي يعتمد فولتية الخطأ و معدل الخطأ كأدخلات له .

يولد المسيطر المقترح اشارة تحكم من خلال اضافة جزء من فولتية المصدر و جزء من تيار المحمالة بعد ترشيحه الى اخراج التراكمي للمسيطر المضبب بعد تغذيته باشارة خطأ الفولتية و اخرى تمثل الفرق ما بين فولتية الاخراج و قيمتها بعد ترشيحها بمرشح ترددات واطنة . ابدى محول التيار المستمر ( المسيطر عليه بالمسيطر المقترح) اداء عال تحت ظروف تغيرات صغيرة و كبيرة في كل من فولتية الادخال و مقاومة الحمل اضافة الى سرعة الاستجابة لمتطلبات مرجع الاخراج

### 1-Introduction

DC/DC boost converters are used where there is a need to supply DC loads from DC sources and the required DC voltages are higher than those of the DC sources. They are also used to interface the battery storage systems and ultra capacitors storage systems with the utility grid. Functionally, they play the roles of step up transformers but in the DC domain which lacks the existence of such transformers.

The step up transformation facility of DC/DC boost converter is function of its power circuit structure and the driving controller which initiates and controls the cyclic operating sub topologies of this power circuit.

The essential role, this converter plays

in power electronic field, motivated researchers to study its behavior [1] and creates an approximate mathematical models based control approaches [2]. The accuracy of the mathematical models are limited because it is difficult to get an accurate model of DC/DC boost converter. This dilemma has been solved by proposing fuzzy logic based controllers [3-6].

### 2.DC/DC boost converter's power circuit analysis

The basic structure of the DC/DC boost converter's circuit with resistive load is shown in Fig.1. It comprises an inductor, transistor switch, diode switch, filtering capacitor, and load resistance. It is powered from DC voltage source,  $V_s$ .

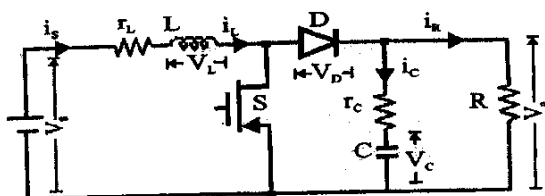

Fig.1 : Boost converter power circuit elements

$$V_s = r_L i_L + L di_L/dt \quad \text{--(1)}$$

$$di_L/dt = -r_L i_L/L + V_s/L \quad \text{--(2)}$$

$$i_C = -i_R \quad \text{--(3)}$$

$$v_O = v_C + r_C i_C$$

$$i_C = C dv_C/dt$$

$$v_O = v_C + r_C C dv_C/dt$$

$$i_R = v_O/R$$

$$i_R = [v_C + r_C C dv_C/dt]/R$$

$$C dv_C/dt = - [v_C + r_C C dv_C/dt]/R$$

$$dv_C/dt = -v_C / \{C(R + r_C)\} \quad \text{--(4)}$$

**Second topology:** ( S is OFF and D is ON)

$$i_L = i_C + i_R$$

$$i_C = C dV_C/dt$$

$$v_O = (v_C + r_C i_C)$$

$$v_O = (v_C + r_C C dv_C/dt)$$

$$i_L = C dv_C/dt + (v_C + r_C C dv_C/dt)/R$$

$$i_L = [C(R + r_C)/R] dv_C/dt + v_C/R$$

$$dv_C/dt = [R/\{C(R + r_C)\}] i_L - [1/\{C(R + r_C)\}] v_C \quad \text{--(5)}$$

$$V_s = r_L i_L + L di_L/dt + v_O$$

$$V_s = r_L i_L + L di_L/dt + r_C C dv_C/dt + v_C$$

$$V_s = [r_L + \{r_C R / (R + r_C)\}] i_L + L di_L/dt + \{1 - 1/(C(R + r_C))\} v_C$$

$$di_L/dt = V_s/L - [r_L + \{r_C R / (R + r_C)\}] i_L / L + \{1 - 1/(C(R + r_C))\} v_C / L \quad \text{--(6)}$$

### 2.1 Power circuit distinct sub topologies

The cyclic and complementary switching of the transistor switch and the diode switch are restricted into one of three modes. These are:

Mode 1: The transistor is ON and the diode is OFF.

Mode 2: The transistor is OFF and the diode is ON.

Mode 3: The transistor is OFF and the diode is OFF.

Each of the above mode of operation gives raise to a unique circuit topology. These unique topologies are shown in Fig.2 and their describing differential equations can be derived as follows :

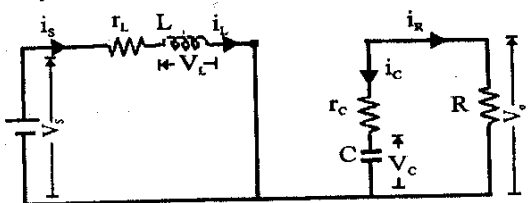

a: 1<sup>st</sup> topology: ( S is ON and D is OFF)

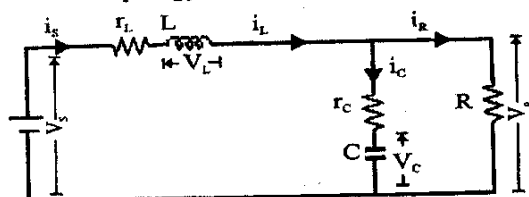

b: 2<sup>nd</sup> topology: ( S is OFF and D is ON)

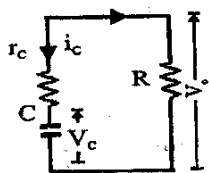

c: 3<sup>rd</sup> topology: ( S and D are OFF)

Fig.2: Possible cyclic topologies of boost converter.

**Third topology:** ( S and D are OFF )

This topology is a part of the first topology and it is defined by equations (3) and (4) in addition to:

$$i_L = 0 \quad \text{--(7)}$$

## 2.2 Values of the energy storage elements

These elements are represented by the inductance L and the capacitor C. The value of the inductance determines the mode of operation ( continuous or discontinuous current conduction mode) and the current ripple ( inductor current ripple). That of the capacitor determines the output voltage ripple . So, proper selection of these two components keep the converter in the required mode of operation and the ripple of the input current and output voltage within the allowable range.

### 2.2.1 Inductance calculation criteria

Referring to Eq.(1), one can see that the inductor voltage is slightly less than the supply voltage ( $V_S$ ). Knowing that  $r_L$ , which stands for the series resistance of the inductor wire, is small  $V_S$  can be approximated by:

$$V_S = L\Delta i_L / \Delta t \quad \text{---( 8)}$$

Where  $\Delta i_L$  represents the peak of the input current ripple,  $\Delta t = D_1 T_S$  represents the ON period of the transistor switch S in term of the duty ratio( $D_1$ ) and the switching signal period ( $T_S$ ).

From Eq.(8) , the inductance value that ensures continuous current mode of operation should be :

$$L > V_S D_1 T_S / \Delta i_L \quad \text{--(9)}$$

To get the highest value of the inductance:

- 1- The maximum value of  $V_S D_1$  should be taken. This can be obtained by substituting the expected input voltage range in  $V_S D_1 = V_S (1 - V_S / V_{ref})$  and taking the highest.
2.  $\Delta i_L$  is taken in term of the required input ripple ( $\Delta i_L =$  twice the input current change during the on time of the transistor).

### 2.2.2 Capacitance calculation criteria

The capacitor should be assigned a value that ensures a pre specified output voltage ripple range. Eq.(3) states that the capacitor carries the load current during the turn on period of the transistor switch. The The maximum discharge occurs during this period. The worst case belongs to that with the lowest input voltage and highest output drawn power . So the capacitor is:

$$C > I_{OMAX} D_{1MAX} / (\Delta V * F_S) \quad \text{--(10)}$$

Where  $I_{OMAX}$  represents the output current maximum loading,  $D_{1MAX}$  represents the duty ratio under minimum input voltage,  $\Delta V$  represents the allowable output voltage ripple, and  $F_S$  is the switching frequency

### 2.3 The nonlinear behavior of the DC/DC boost converter

As it is clear from Fig.1, the boost converter consists of linear elements represented by the resistor, inductor, capacitor and nonlinear ones represented by the switching elements addressed by the transistor and the diode.

The cyclic and complementary switching of these nonlinear elements under the control of pulse width modulation give raise to cyclic witching of linear circuit topologies (Fig.2). These linear circuit topologies lead to nonlinear and time varying behavior[1].

## 3. The driving controller

### 3.1 The driving controller's functions

The controller is responsible to keep the converter output voltage equal to that specified with the reference input. This is the sound function of the controller, but it must be achieved along with keeping the input current ripple and the output voltage ripple within the range of  $\pm 10\%$  of the rated load current for the input current ripple and  $\pm 0.5\%$  of the nominal voltage for the voltage ripple [ 2 ].

### 3.2 Fuzzy logic based controllers in boost converter environment

The foregoing discussion states that DC/DC boost converter is inherently nonlinear. This inherent nonlinearity restricts the validity of the driving controller based on small signal linearized models[3] and recommends the adopting of nonlinear approaches.

Fuzzy logic based controllers are nonlinear regulating systems [3-6]. They are capable of coping with the nonlinear and time varying behavior of the boost DC/DC converter because they emulate the expert operator's behaviors when dealing with such systems. The expert may or may not be aware of what is going inside the system, he or she is driving. The decisions taken by the expert are extracted from his or her own accumulated historical experience. In fact, this is the way, the fuzzy logic based controllers drive their assigned processes .

## 4. Design of the controlled boost system

The block diagram representation of the boost converter & its proposed controller is shown in Fig.(3 ). It consists of two parts, namely the power circuit & the controller.

The power circuit acts as an interface between the DC input voltage source and the DC load.

The controller controls the energy flow through the power circuit in such away that keeps the load voltage, input current ripple and the output voltage ripple as desired irrespective of the input supply voltage or load resistance variation.

### 4.1 Power circuit design

#### 4.1.1 System requirements

The system under consideration is intended to achieve the following design requirements:

Input voltage =  $28 \pm 25\%$  (V)

Output voltage = 50 V

Nominal load resistance =  $10\Omega$

Max. input current ripple  $\leq 10\%$  of the nominal load current

Max. output voltage ripple  $\leq 0.5\%$  of the rated output voltage.

Switching frequency = 100kHz.

#### 4.1.2 Selected components

To achieve the above requirements and depending upon Eq.(9) and Eq.(10), the required energy storage elements are recommended to be :

$L \geq 135\mu\text{H}$

$C \geq 360\mu\text{F}$

$r_L$  has been assumed to be  $0.005\Omega$

$r_C$  has been assumed to be  $0\Omega$

### 4.2 Controller design

#### 4.2.1 The architectures of the proposed controllers

As it is clear from Fig.3, the proposed controller solves the control requirements by generating switching command composed of three parts represented by:

- 1- The output of a PI like fuzzy controller: The fuzzy controller has been supplied with the output voltage error and a signal derived from the subtraction of the output voltage from its low pass filtered version to reflect the rate of change of the output voltage error. The main target of this part is to keep the converter output voltage equal to that of the reference.
- 2- Weighted part of the low pass filtered inductor current: it acts as a damper during the sudden changes of the load resistance and input voltage level.
- 3- Weighted part of the input voltage: This is to add an extra damping during the changes of the input voltage.

#### 4.2.2 Membership functions of the fuzzy input variable

The behavior of the output voltage of the boost converter after the occurrence of disturbances depends upon the sizes of the disturbances and also the progress of time .

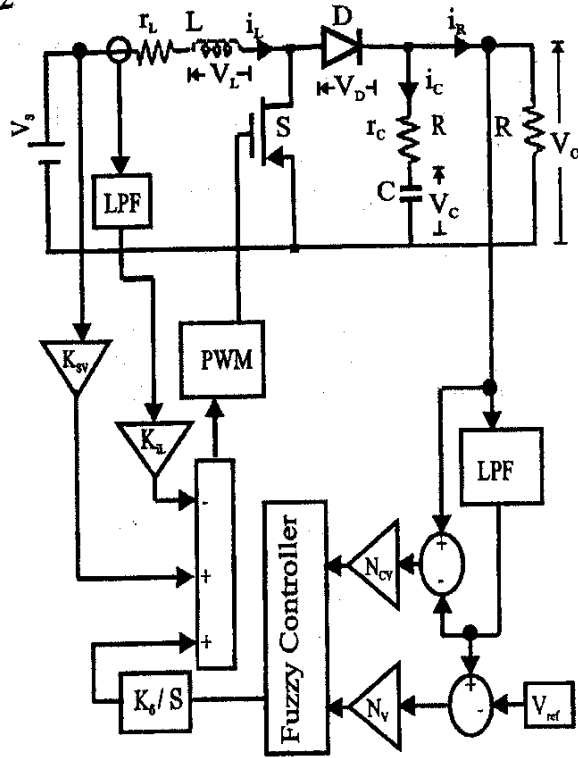

Fig.3 : The boost converter power circuit and its proposed controller.

The voltage may jumps up or down very far from the set point, may not very far from the set point , or may around the set point. This suggests five variables for the voltage error ( $V_o - V_{ref}$ ) as shown in Fig.4(a). Also the transition speed may be classified into five categories as shown in Fig.4(b).

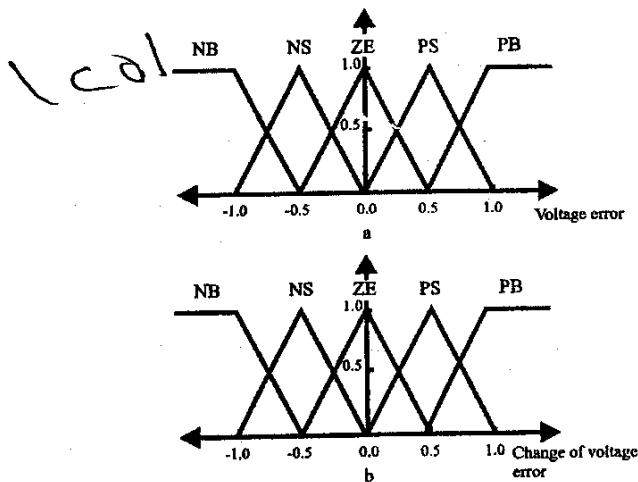

Fig.4: Fuzzy controller membership functions:  
a) Voltage error; b) Change of voltage error.

### 4.2.3 Membership functions set of the fuzzy output variable

The output fuzzy variable labels reflect the amount of correction required for the situation under consideration. To get compromise solution between complexity and control smoothness, seven labels have been selected (Fig.5).

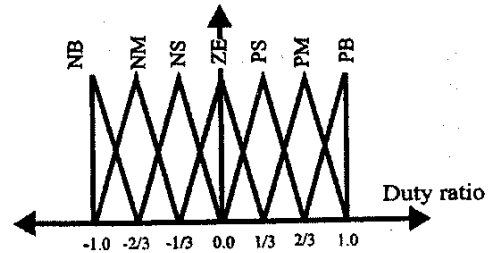

Fig.5: Fuzzy controller output membership functions.

### 4.2.4 Fuzzy inference rules tables

Table(1) summarizes the rule set for the fuzzy controller. The selection of the rules weights has been done through two steps. In the first step they have been initialized to the centers of the output fuzzy variable labels adopted. In the second step they have been modified experimentally.

Table 1: Rules set of the proposed controller.

		Voltage error				
		NB	NS	ZE	PS	PB
Change of voltage error	PB	1.0	0.0	-0.2	-0.5	-1.0
	PS	1.0	0.1	-0.1	-0.35	-1.0
	ZE	1.0	0.2	0.0	-0.2	-1.0
	NS	1.0	0.35	0.1	-0.1	-1.0
	NB	1.0	0.5	0.2	0.0	-1.0

### 4.2.5 Fuzzy controller implementation

In the current work, the fuzzy logic based controller has been implemented through the proposed model presented shown in Fig.6.

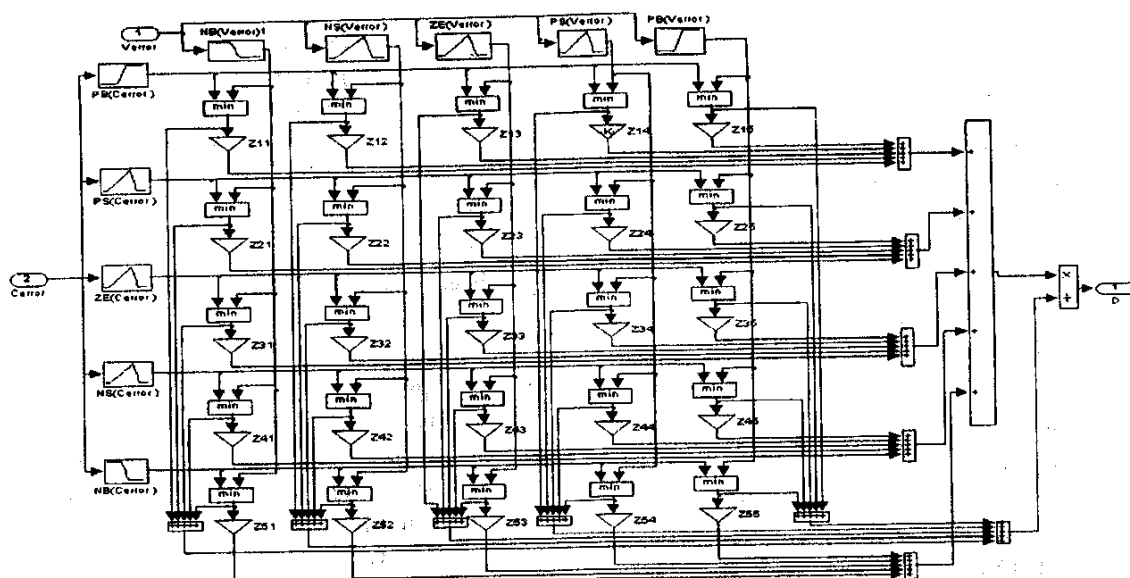

Fig. 6 Matlab/Simulink modeling of the proposed fuzzy controller

#### 4.2.6 Selection of $N_V$ , $N_{CV}$ , $K_\delta$ , $K_{SV}$ , & $K_{iL}$

The normalization factors of the voltage error ( $N_V$ ), normalization factors of change of voltage error ( $N_{CV}$ ), incremental gain of the fuzzy controller ( $K_\delta$ ), reduction gain factor of the fed part of the input voltage ( $K_{SV}$ ), and reduction gain factor of the fed inductor current ( $K_{iL}$ ) have been selected through testing the system performance under different settings of these factors. The ones selected were those whose static and dynamic performances were satisfactory from the point of view of stability, settling time, peak value, and valley value at the time of disturbance. The setting were:

$N_{CV}$	$N_V$	$K_\delta$	$K_{SV}$	$K_{iL}$
4	0.2	1350	0.05	0.01

### 5 Simulation results and discussion

To test the performance of the proposed controller, the controller has been used to

drive DC/DC boost converter with the requirements given in subsection(4.1.1).

The validity examination has been done through :-

- 1- Driving the power circuit with different values of input supply voltage.
- 2- Loading the power circuit with different values of load resistance.
- 3- Applying different output voltage reference settings.

The results of these tests are plotted in Fig.7 to Fig.17, where:-

Fig.7 displays the transient response of the output voltage and the inductor current under nominal load ( $10\Omega$ ) and  $\pm 25\%$  of nominal value of the input voltage step changes. The responses ensure the ability of the proposed controller in keeping the output voltage equal to that defined by the reference value. Also they ensure that, at the time of change occurrence, the current and voltage over shoots, and settling times are limited to an acceptable levels.

From Fig.7, one can see that under the load for which the converter has been designed, the system gives an excellent response irrespective of the step down and up of the input voltage in the range of

$\pm 25\%$ .

Figs. 8 and (9) show the transient performance under an input voltage of 28V and for given loading resistance ranging from  $5\Omega$  to  $50\Omega$ . From these figures, the following points can be extracted:

1- The proposed system can start and settled within a time of 7ms for loading range from 50W to 500W (load resistance of  $50\Omega$  to  $5\Omega$ ).

2- At steady state, the maximum output voltage deviation occurs at the maximum loading condition ( $5\Omega$ ) and it is less than 0.5% of the nominal output voltage.

3- The inductor current deviation is within the range of  $\pm 10\%$  of the output current.

Figs. 10 and (11) do the same as that of Figs. 8 and (9) but under an input voltage of 35V which is greater than the nominal by 25%. The results state that under such driving voltage, the following points bubble up:-

1- For  $5\Omega$  and  $10\Omega$ , the system start satisfactorily and need a time up to 7 ms to settled down.

2- As the load resistance increases, the settling time increases too. For  $50\Omega$ , it reaches 21 ms.

3- Under this increased input voltage, the voltage and current deviations are within the standard for the different loading.

Figs. 12 and (13) belong to a driving voltage of 21 V which is less than the nominal by 25%. Under this supply voltage The following are observed:-

1- The minimum settling time occurs at the design load. It takes about 14 ms.

2- For  $5\Omega$  and  $50\Omega$  the settling time is about 22ms.

3- The voltage and current deviations are with in the standards.

Figs. 14 to (16) display the output voltage and inductor current responses under load resistance step changes from the nominal value ( $10\Omega$ ) to the one attached to the drawing and then back to the nominal and under an input voltage of  $25 \pm 25\%$ . The drawings indicate the following:-

1- Under an input voltages of 28V and 35V, the performance is good from the point of

view of overshoot and settling time. The maximum over shoot is 10%.

2- With the lower limit of the input voltage (21V), the converter returns to its steady state but after exposing the system to slightly increased over shoots (around 14%) as compared to those under 28V and 35V (less or equal to 10%).

3- Load step changes from  $10\Omega$  to  $50\Omega$  represents the best range for the three voltage levels.

Fig. 17 displays the ability of the system in keeping track with the sudden changes of the reference voltage. It has been subjected to  $\pm 20\%$  step changes. The results noted down the followings:

1- Under supply voltage greater than or equal to the nominal one (28V, 35V), the system jumps to the new setting after a maximum time of 8msec.

2- Poor tracking ability is obtained if the system continued to be driven by the low voltage level (21V).

## 6. Conclusion

Fuzzy logic based controller, supported with a low pass inductor current and an input voltage weighted signals, has been proposed. The fuzzy controller has been driven by voltage error signal and another signal derived by subtraction of the output voltage from its low passed version.

The simulated results recited the following remarks:-

1- For the design specification, the system performed well from the point of view of steady state error, voltage ripple, inductor current ripple, settling time, and overshoots values.

2- Under  $\pm 25\%$  variation in the input voltage, the converter exhibited acceptable recovery speed ( $< 4\text{ms}$ ) with maximum overshoot of 7% of the rated voltage occurred at the transition of the supply from 21V up to its design value (28V).

3- For load resistance toggling, the converter excellent controllability.

4- The converter can start well under over load and light load conditions.

## 7. References

- [1]- Chik. Tse and Mario Di Bernardo “ Complex behavior in switching power converters “ Proceedings of IEEE, Vol. 90, No. 5, May 2002, pp. 768-781.
- [2]- P. T. Krien, “ Elements of Power Electronics”,NewYork, Oxford University Press, 1998.
- [3]- W. So, C. Tse, and Y. Lee, ”Development of a fuzzy logic controller for DC/DC converters: design, computer simulation, and experimental evaluation”, IEEE Trans. Power Electronics , Vol. 11, No. 1, May 1996, pp. 24-32.
- [4]-Fang Hsien Wang and C.Q. Lee, “ Comparasion of fuzzy logic and current-mode control techniques in buck , boost , and buck/boost converters “, Proc.of IEEE PESC 1995 , pp. 1079-1085.
- 5-Sung -hoe and G. Park , “ An adaptive fuzzy controller for power converters “ IEEE, International fuzzy system conference Proceedings, August 1999, pp. 434-439.
- 6-Dake He and R.M. Nelms, ” Fuzzy logic average current-mode control for DC-DC converters using an inexpensive 8-bit microcomputer“, 2004 39<sup>th</sup> IEEE IAS 2004, Annual Meeting, seattle, Washington, October 2004.
- [7]-Cornelius T . Leondes, “ Fuzzy logic and expert systems applications “, Academic Press 1998.



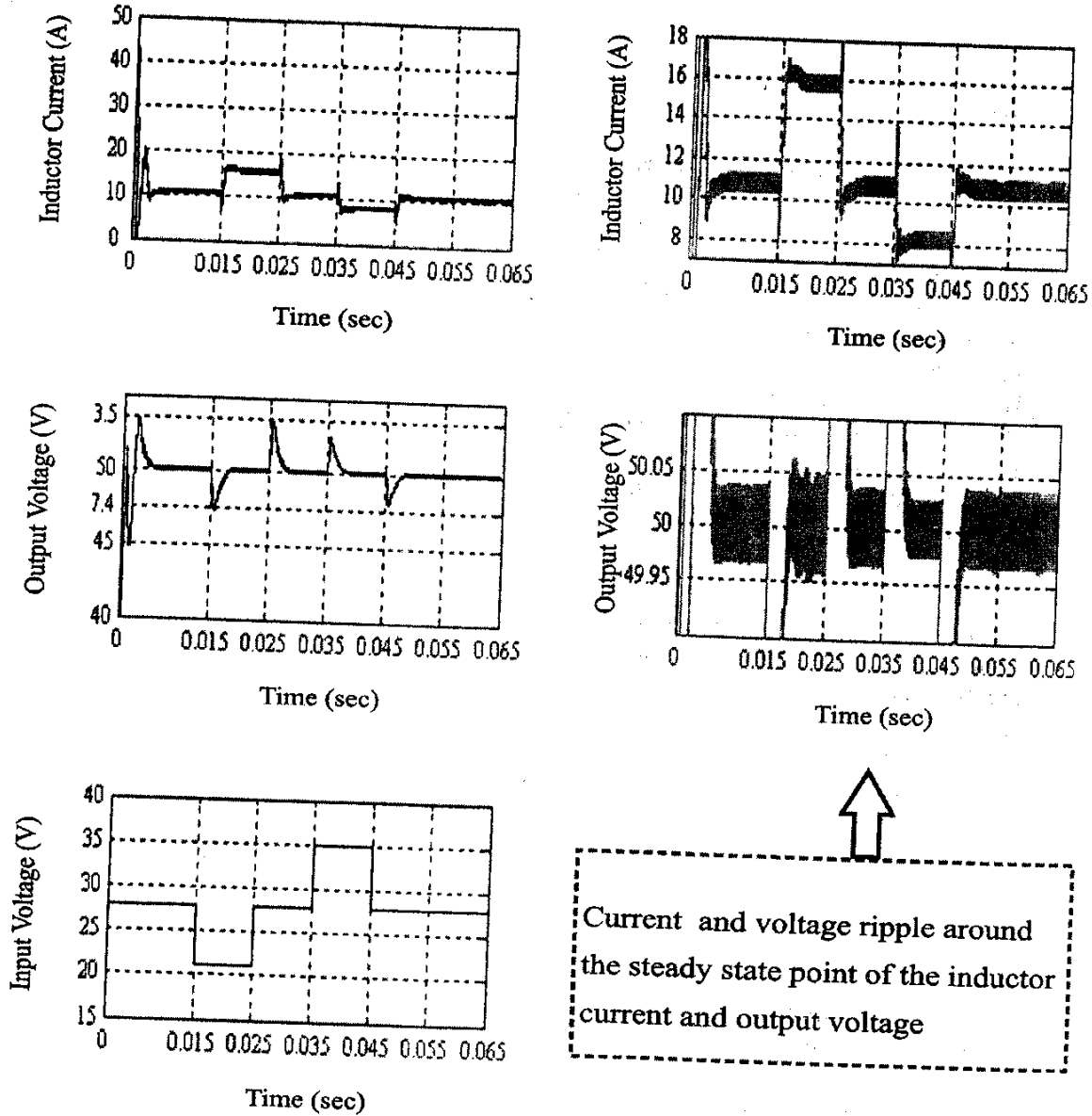
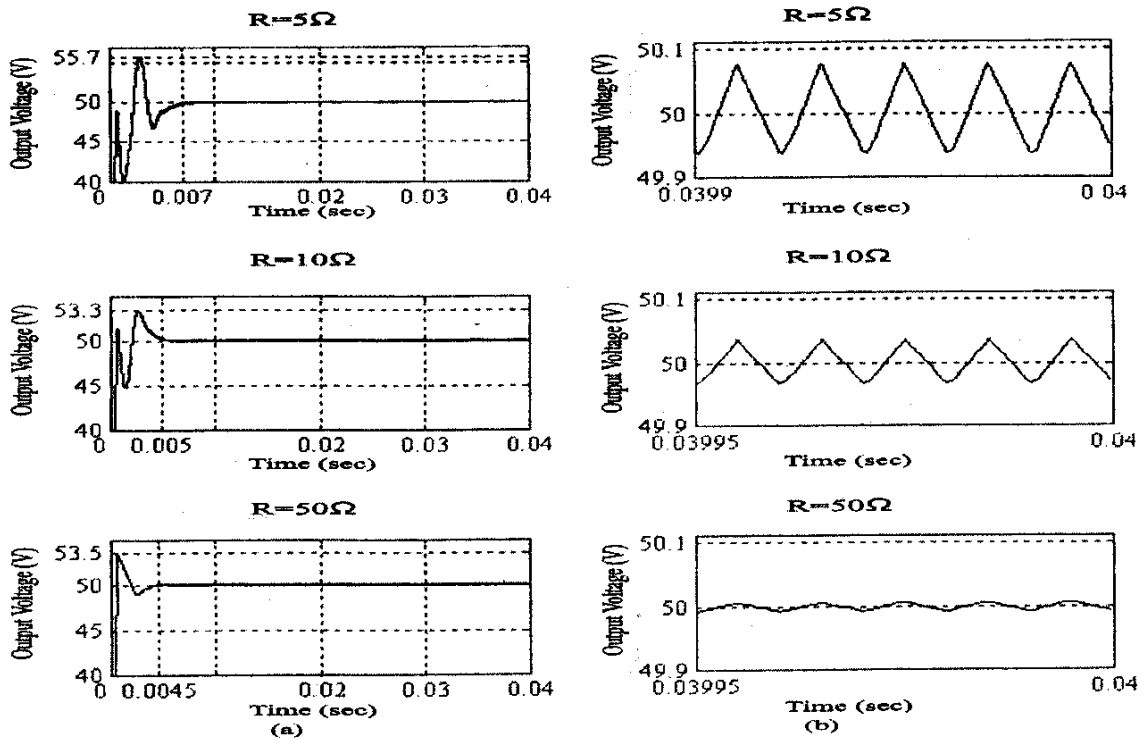
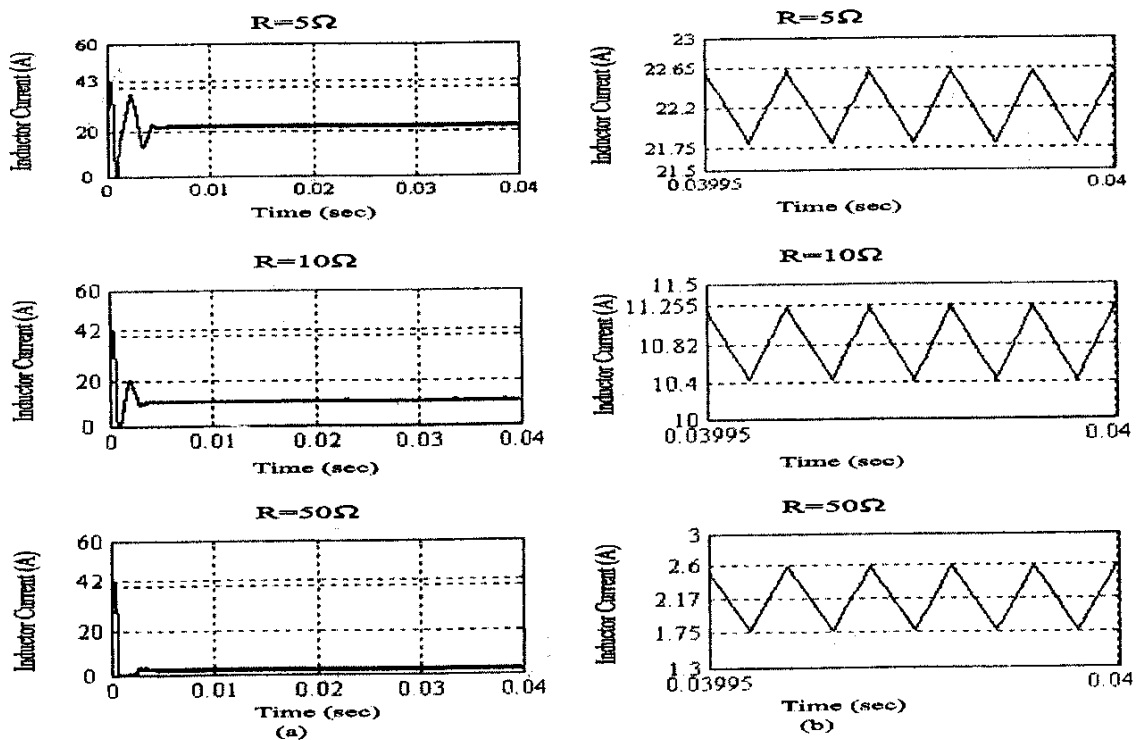

Fig.7: Voltage and current responses under 10Ω load resistance and an input voltage of 28 ± 25%V.



**Fig.8 : Voltage response under different loading and an input voltage of 28V: a) Voltage response; b) Voltage ripple under steady state**



**Fig.9 : Current response under different loading and an input voltage of 28V: a) Inductor current response; b) Inductor current ripple under steady state**

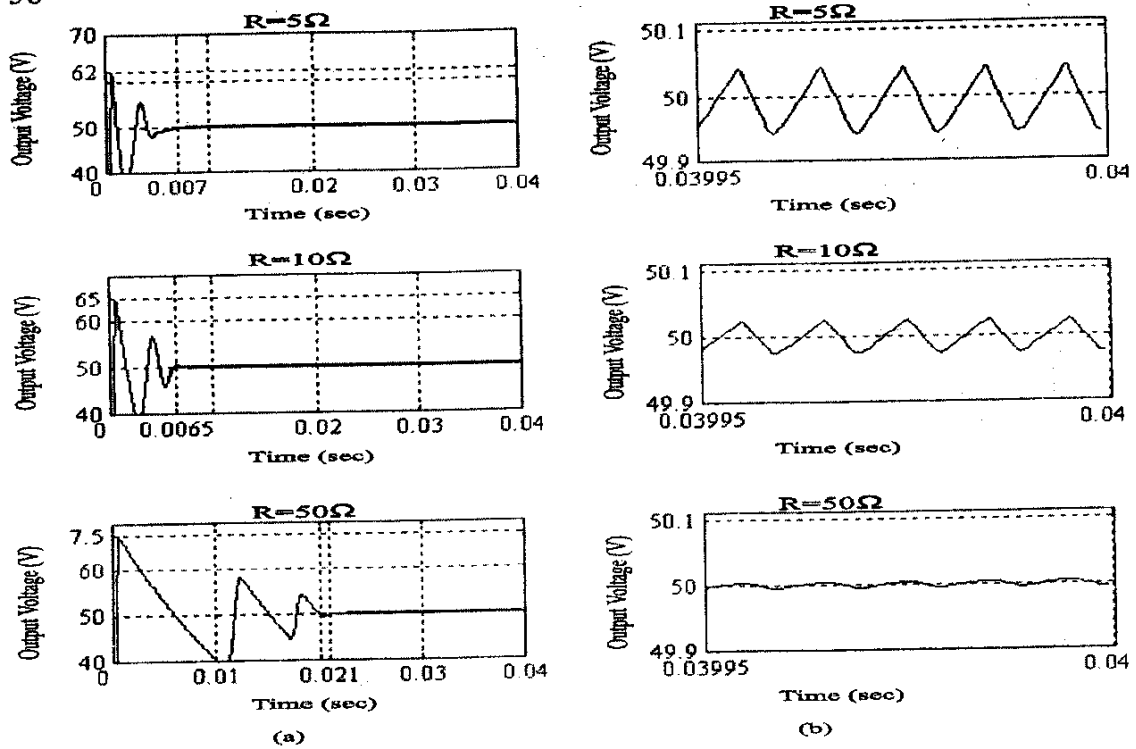

Fig.10 : Voltage response under different loading and an input voltage of 35V: a) Voltage response; b) Voltage ripple under steady state

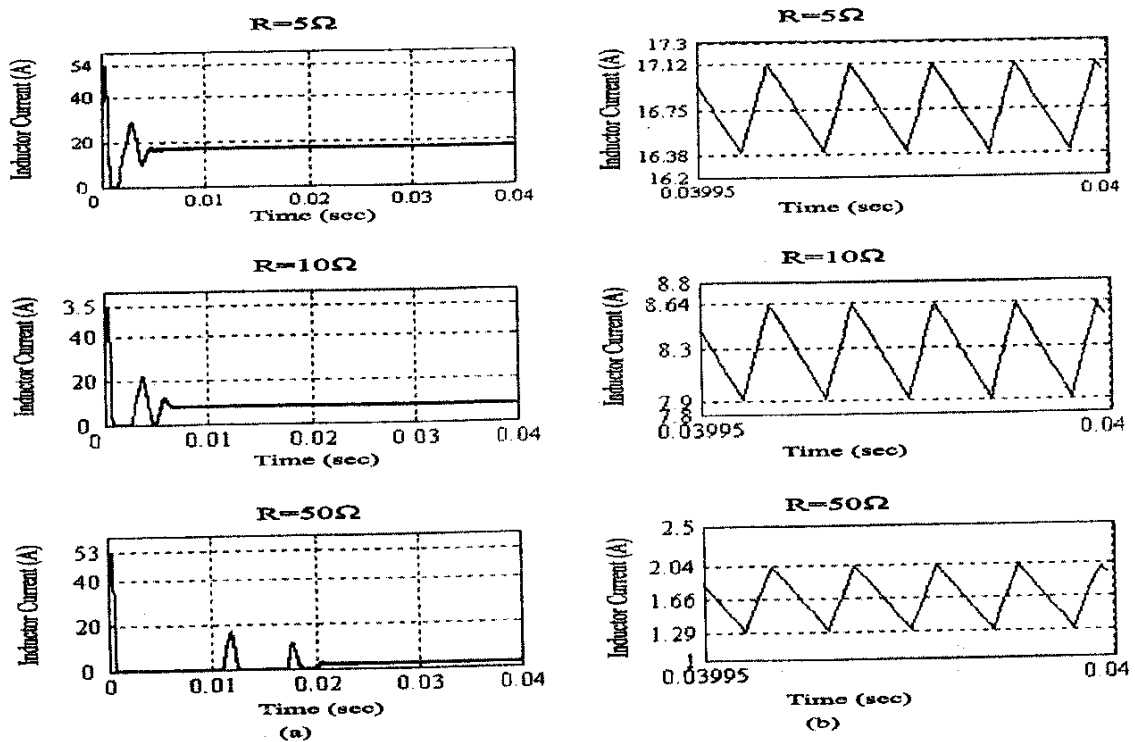
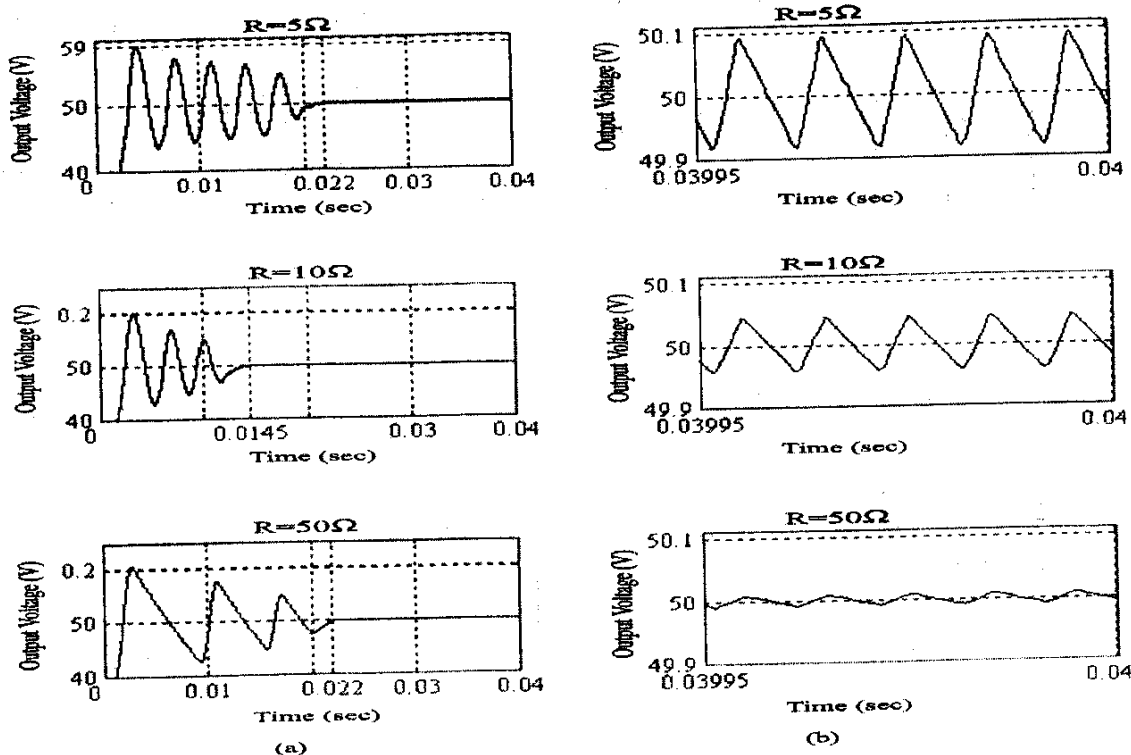
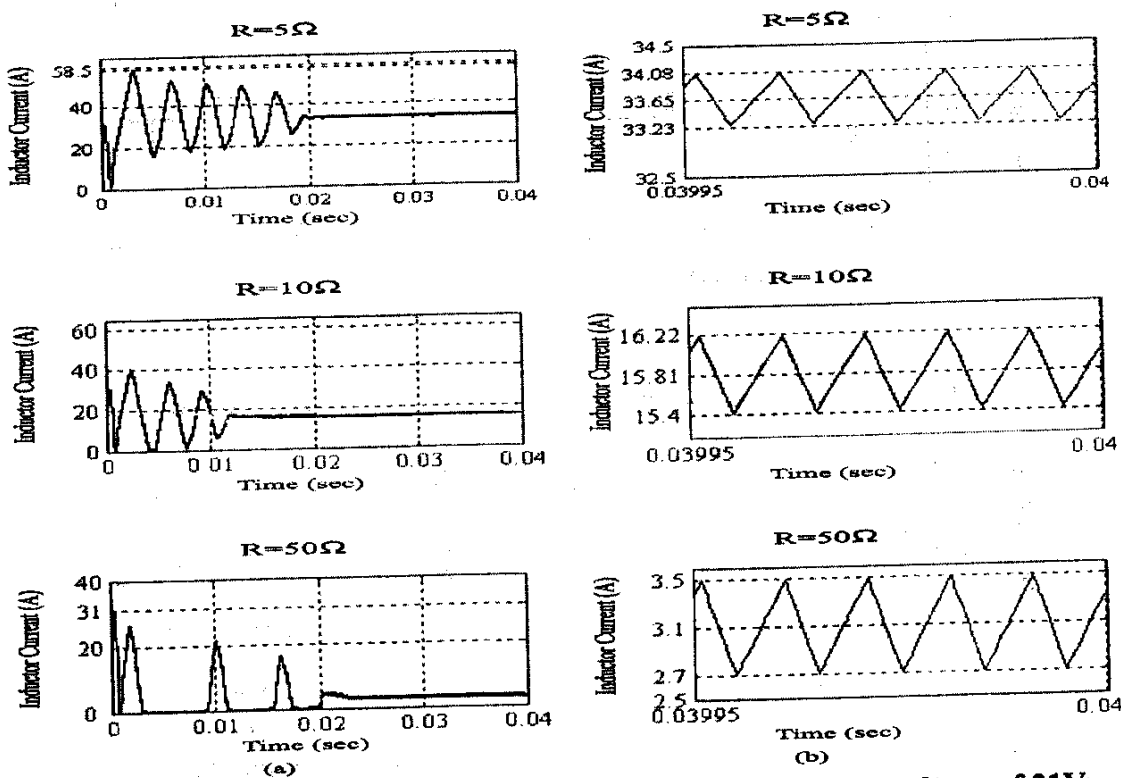

Fig.11 : Current response under different loading and an input voltage of 35V: a) Inductor current response; b) Inductor current ripple under steady state



**Fig.12 : Voltage response under different loading and an input voltage of 21V:  
a) Voltage response; b) Voltage ripple under steady state**



**Fig.13 : Current response under different loading and an input voltage of 21V:  
a) Inductor current response; b) Inductor current ripple under steady state**

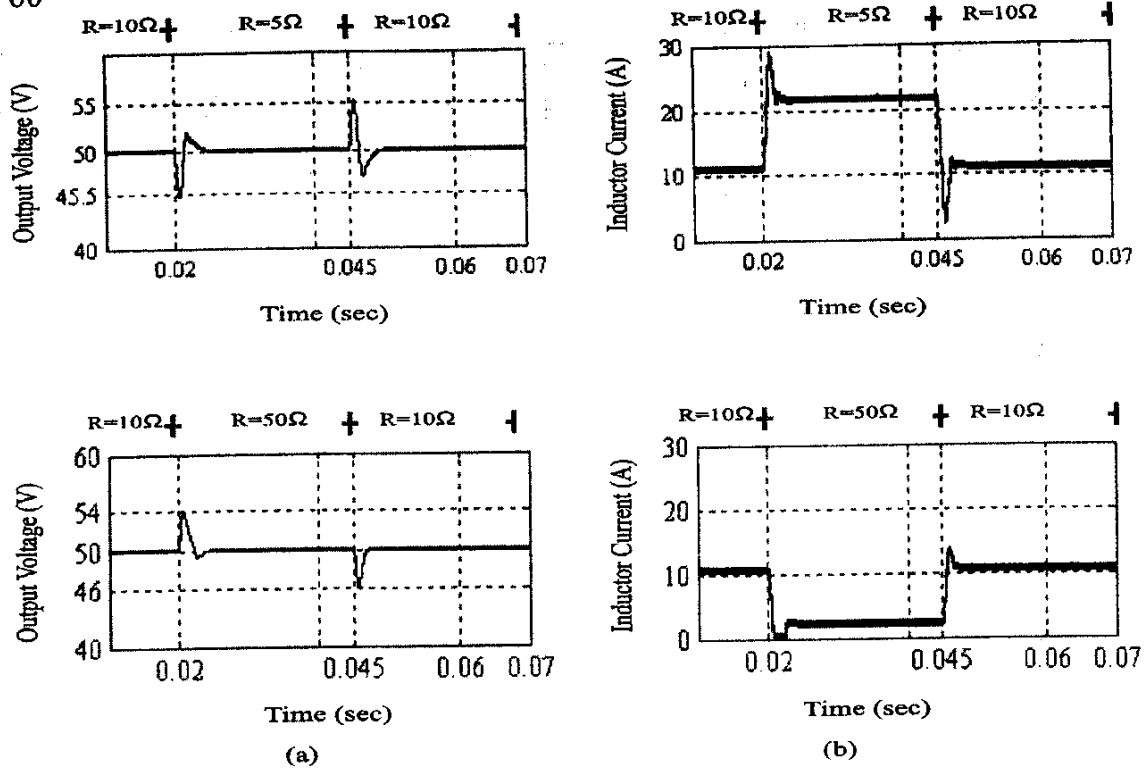

Fig.14: Simulation results under load resistance step changes and an input voltage of 28V: a) Voltage response; b) Current response.

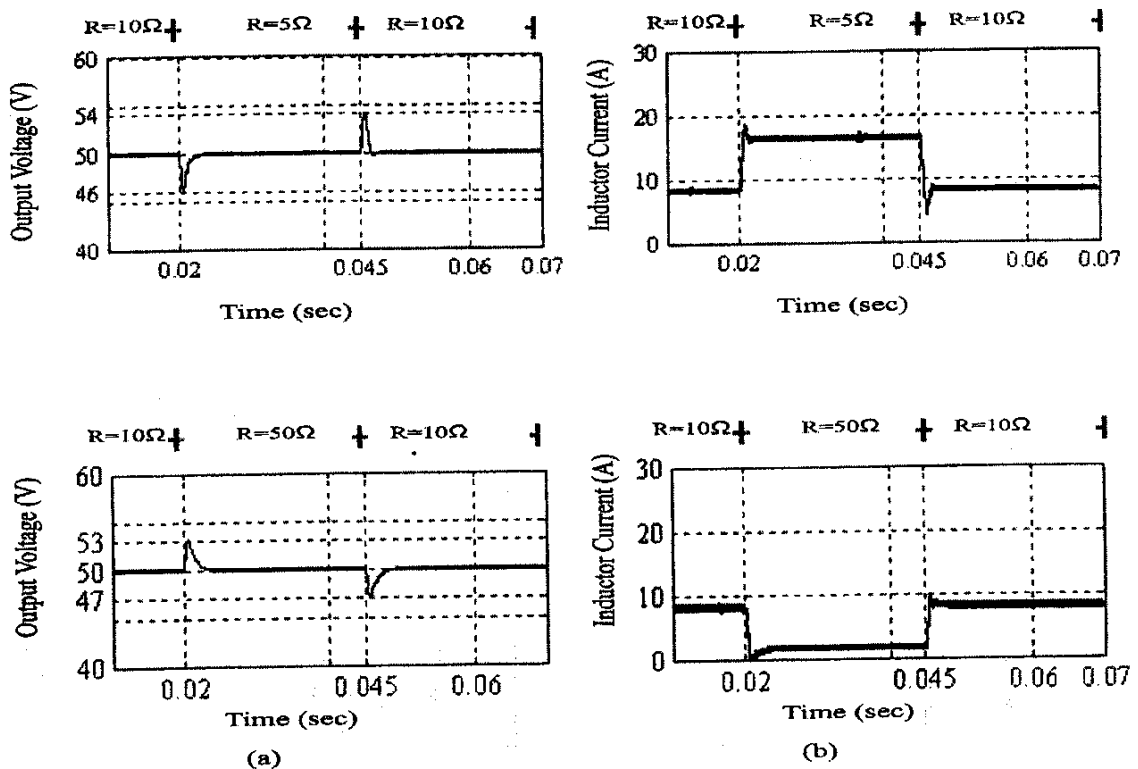
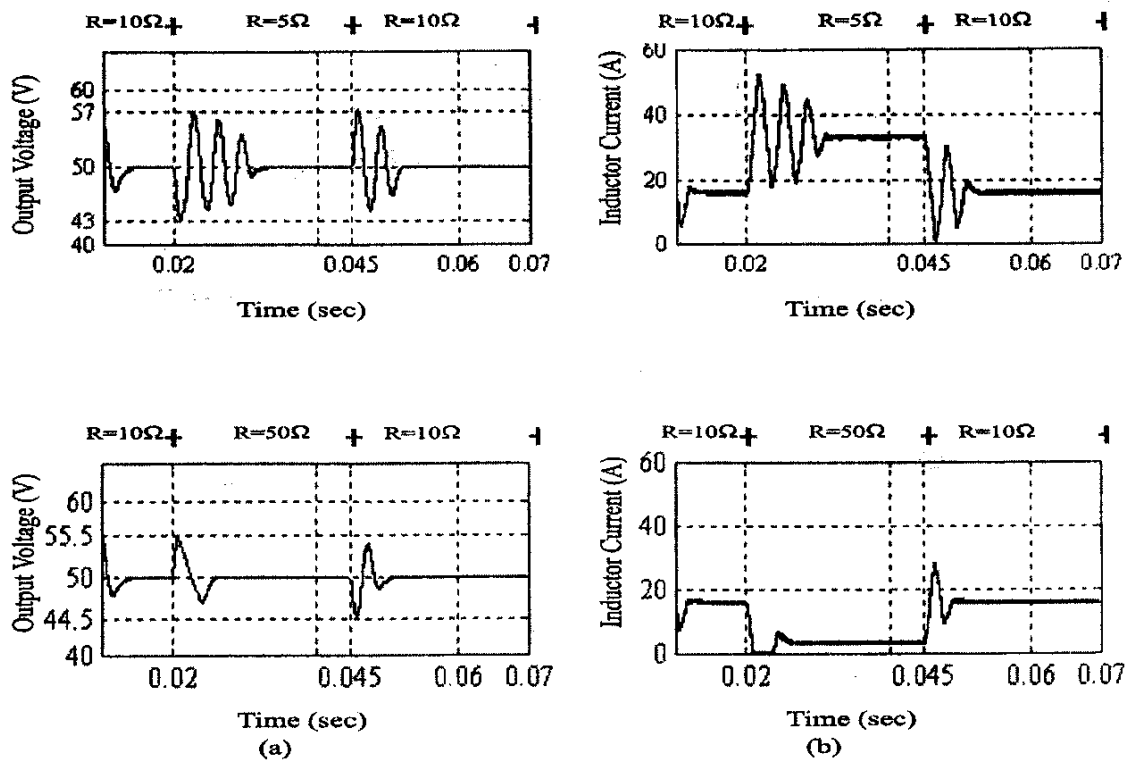
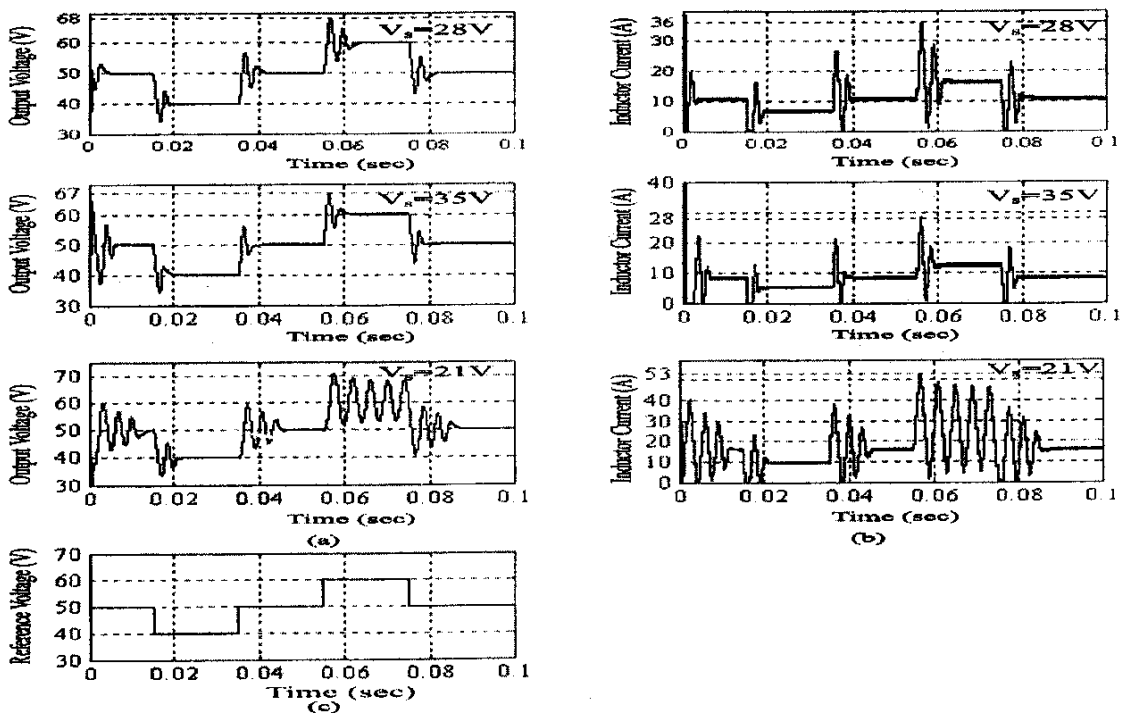

Fig.15 : Simulation results under load resistance step changes and an input voltage of 35V: a) Voltage response; b) Current response.



**Fig.16 : Simulation results under load resistance step changes and an input voltage of 21V: a) Voltage response; b) Current response.**



**Fig.17 : Simulation results under step variation of the reference voltage at a given input voltage : a) Voltage response; b) Current response; c) Reference voltage.**